

Resolute Marine Energy: Power in Waves

Cate Reavis, Ezra Zuckerman

Working in ocean energy is only an engineering challenge. It's not a science challenge the way so many renewable energy technologies are. For ocean energy, it's about building something that stays put and operates reliably for a period of time and ultimately produces what we call a levelized cost of energy that's comparative. And one of the impediments is that there haven't been enough devices deployed to really start exploring how inexpensive they can get. We're the wind industry 10 or 20 years ago, depending on whether you're an optimist or pessimist.

– Bill Staby, RME CEO

For the 700,000 people living in Ugu, a municipality in the province of KwaZulu-Natal on South Africa's east coast, potable drinking water was very expensive: \$1.00/m³ after a government subsidy of \$0.50. In comparison, a cubic meter of water in New York City was \$.92/m³. (The Gross Domestic Product (GDP) per capita (PPP) in the United States was four times higher than that of South Africa.¹)

It was no mystery as to why drinkable water was so costly: Like many coastal communities in South Africa, Ugu suffered from a weak electric grid. While it had access to an endless supply of ocean water, desalinating it required the use of a diesel generator. In addition to its noxious CO₂ emissions, diesel fuel was prohibitively expensive for many poor communities. Though a variety of local rivers, dams, and aquifers contributed to Ugu's water supply, a significant percentage of water was pumped in from other regions.

¹ In 2012, the GDP per capita (PPP) in South Africa was \$11,400 and \$49,900 in the United States (World Bank).

Resolute Marine Energy (RME) Founder and Chief Executive Officer (CEO) Bill Staby and Chief Operating Officer (COO) Olivier Ceberio (MBA '08) believed that RME's wave-driven desalination system, known as Wave₂O™, would provide a community like Ugu with cheaper water using renewable energy in the form of ocean waves. In May 2012, after nearly three-and-a-half years of discussions with the municipality of Ugu, RME was one step closer to making its vision a reality when the Development Bank of South Africa expressed interest in funding the South African side of a pilot to test the Wave₂O™, namely the costs associated with site testing and permitting. With the backing of a local funder, Staby and Ceberio were confident that RME would be able to land impact investors to fund the \$6 million it would take to complete testing on the Wave₂O™.

But while the stars had started to align for the young company, Staby and Ceberio were debating three strategic approaches the company could take as it worked toward commercializing its technology. One approach under consideration was developing a wave-driven desalination system that would produce electricity to power a desalination plant. All desalination plants ran on electricity, and RME had spent nearly five years experimenting with wave-energy-produced electricity. Furthermore, RME could apply for U.S. government grants to cover development and testing costs. This approach would require a desalination partner.

The second approach would be a bit more complicated technically, would require significant private investor funding, and would entail using hydraulic power to operate the desalination plant. This was the strategy depicted in RME's business plan. Since margins for water production trumped those for electricity production, this approach was more appealing to RME because the company would indeed be selling water as opposed to electricity. But this strategy would require private sector investment; and in the United States, the private sector had yet to be sold on wave energy. It also would require a desalination partner.

The third approach was arguably the most ambitious and, if successful, would likely be the most financially rewarding. RME was considering the development of a black box, all-in-one solution, whereby it would own both the wave energy conversion system and the desalination plant. In this scenario, RME would be able to market a hybrid desalination system that would produce not only fresh water, but electricity as well. This strategy gave RME a bit of pause because it meant forgoing a desalination partner, which would be technically challenging and thus require more money.

In deciding which approach to take, Staby, Ceberio, and the rest of RME's team of technologists (see **Exhibit 1** for bios), would have to determine, based on its expertise with wave energy, where the company would add the most value. At the heart of this decision was determining whether RME should think of itself as an energy company, a water company, or something more complex.

Wave Energy

Anyone who has spent time in large bodies of water, particularly oceans, is familiar with the power of waves. Generated by the movement of wind over the ocean surface, waves don't have to be much more than a few feet high to steamroll an adult-sized human. Water is 800 times denser than air.²

Since the late 18th century, scientists have been experimenting with and patenting wave energy devices into useful forms of energy, electricity in particular. From the mid-1800s to the 1970s, more than 340 patents for wave-powered devices were granted in the United Kingdom alone.³ The concept behind generating electricity from wave energy was fairly simple: A wave energy convertor (WEC), of which there were many types, converted wave energy into a controlled mechanical force that drove an electrical generator. The generator, in turn, transferred electricity via flexible cables on the seafloor to an onshore power substation that was connected to the electric grid.⁴ With 70% of the Earth's surface covered by water, scientists estimated that between 2 million and 3 million megawatts of electricity per year could be harnessed by wave energy worldwide.⁵

While the concept was simple enough, the wave energy industry had experienced one commercial failure after another⁶ due in large part to environmental factors, including biofouling and rough seas. Because of these failures, it was too early to tell what the negative environmental effects of wave energy systems might be. One of the biggest concerns raised was the potential disruption of marine ecosystems.⁷ As the head of a U.S. political action committee for recreational fishing put it, "Our greatest concern is that they don't do what they did with dams—put a lot of them in the ocean and then just stand back and see what happens. We're advocating a go-slow approach."⁸

Despite the ongoing lack of commercial success, the wave energy space was surprisingly crowded, with most companies operating in Europe or Australia. Those with the most developed technologies included Ocean Power Technologies (OPT), Pelamis, Wave Dragon, Carnegie Wave Energy, Aquamarine, and Oceanlinx, which suffered a significant setback in 2010 when its \$5 million wave energy system sank after being hit with a powerful swell off the coast of Australia. Each company was developing systems using a variety of wave energy technologies. As one industry observer put it, "There's no one-size-fits-all kind of plan."⁹ (See **Figure 1.**) While the United States lagged behind

² Joel Brown, "Nature's Power," *The Boston Globe*, March 1, 2012.

³ J.M. Leishman and G. Scobie, *The Development of Wave Power: A Techno-Economic Study*, Economic Assessment Unit, National Engineering Laboratory, Glasgow, Scotland, 1976, p. 11.

⁴ Mark Sherman, "Wave New World," *Environmental Law*, September 22, 2009.

⁵ Don Hinrichsen, "Harnessing the Power of the Ocean," *Scandinavian Review*, July 1, 2011.

⁶ The first commercialized use of wave-powered energy technology debuted in 2011 when Spain's Mutriku Wave Energy Plant, powered by Voith Hydro Wavegen's oscillating wave columns, began producing electricity for 250 households.

⁷ Mark Sherman, "Wave New World," *Environmental Law*, September 22, 2009.

⁸ Kirk Johnson, "Project Aims to Harness the Power of Waves," *The New York Times*, September 3, 2012.

⁹ *Ibid.*

Europe and Australia in developing wave energy technologies, OPT planned to launch the country's first commercially licensed, grid-connected wave energy device off the coast of Oregon in October 2012. The 260-ton PowerBuoy was expected to provide electricity for 1,000 homes.¹⁰ (Exhibit 2 provides a description of the key players, and Exhibits 3a and 3b show the recent financial results for two publicly traded wave energy companies, Carnegie Wave Energy and OPT.)

Figure 1 Wave Energy Industry

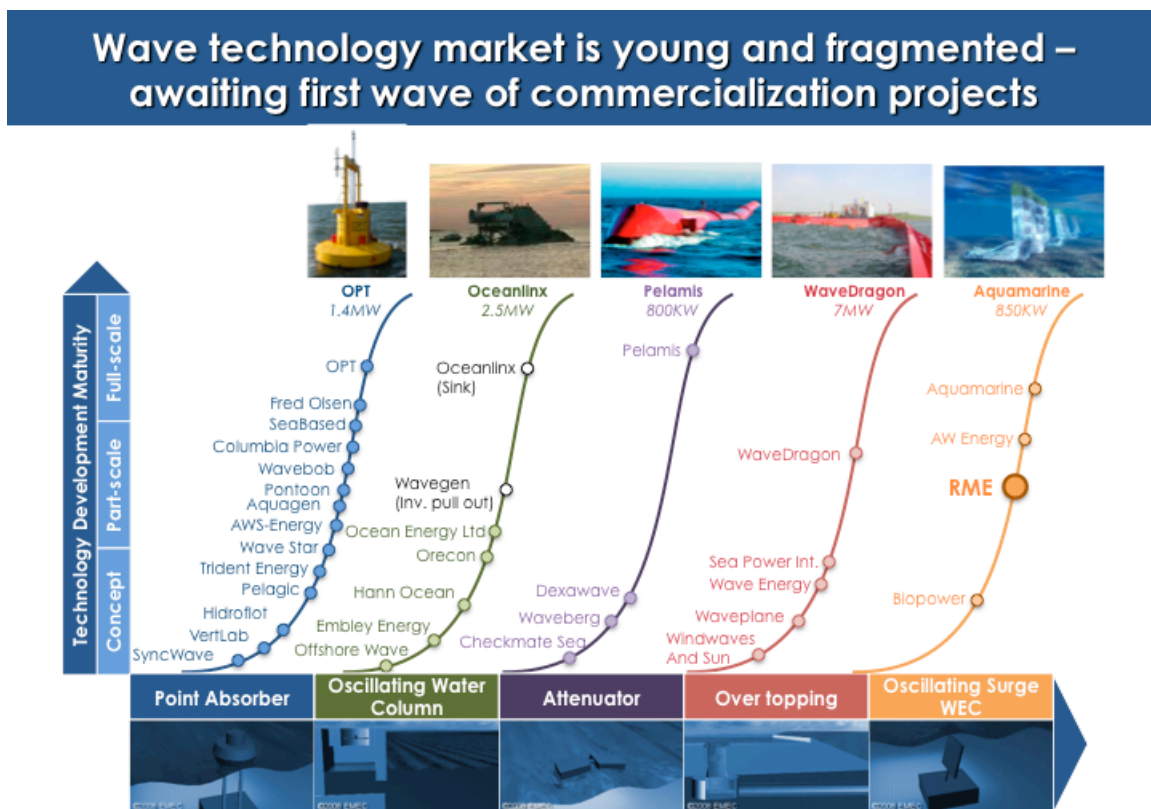

Olivier Ceberio, Resolute Marine Energy, July 2010

1

Most of the wave conversion companies were focusing on developing off-shore systems that would produce grid-scale electricity. According to RME Chief Technology Officer Pat Rezza, the grid-scale electricity market was very difficult to be competitive in: “Clean electric generation is definitely something that needs to be done, but it’s going to be a while before it is cost-competitive. It’s pretty hard to compete with coal in dollars per kilowatt hour. There’s a lot of it, and it’s going to be around for a long time. There’s a lot of money being invested in cleaning up the atmospheric effects of that.”

¹⁰ Ibid.

RME was heading in a different direction, where there were higher margins and fewer direct competitors.

RME

RME's founder, Bill Staby, spent the first 20 years of his career in corporate finance working with early stage companies, where, as he put it, "I had to develop an ability to look over the horizon and identify companies that were going to grow to be something and would, over time, be good-paying clients of the investment banker I was working for." Staby ended his Wall Street career in the mid-2000s after deciding that he wanted the experience of building a company from the ground up.

With three startup experiences under his belt, Staby founded RME in 2007 based partly on his passion for the ocean. He grew up near the coast of Connecticut, where he spent a lot of time sailing and working on boats. Staby became aware of ocean energy during his teenage years when he attended hockey camp near the Bay of Fundy in Nova Scotia, considered the world's most powerful tidal zone.¹¹ "I can remember being there with my father," Staby recalled, "and him saying to me, 'Wouldn't it be amazing if you could harness all the energy that's pouring in and out?'"

As Staby embarked on exploring various wave energy technologies, he kept in mind a few key lessons that he had learned from his previous startup experiences:

The most important thing is not to get too enamored with a particular technology and make sure the technology is being harnessed to actually satisfy a specific customer's need. Look for those niche markets, and specifically look for a customer in a niche market that you can get in a bear hug and work together with to develop the technology to satisfy their needs. After that, the appropriate technology will generally suggest itself to you.

After surveying the wave energy industry, Staby concluded that RME would not succeed if it followed the utility-scale-electricity path that other companies in the space had chosen. Wave energy would not be cost-competitive with coal or natural gas for some time. In addition, getting the necessary regulatory and permitting authorization to launch an electricity-producing wave energy pilot in the United States would likely take up to five years. Staby instead turned his attention to the niche markets, namely offshore aquaculture, powered by wave energy. With funding from the National Oceanic and Atmospheric Administration (NOAA), RME developed a WEC to power an aquaculture cage, but soon discovered that there were no near-term revenue opportunities. Staby admitted that RME had arrived too early to the market. He believed that there would be a market, but it likely wouldn't be a thriving one for up to 10 years.

¹¹ <http://bayoffundy.com/about/highest-tides/>.

Aware of the water crisis that afflicted many developing countries and the energy required to power a reverse osmosis (RO)¹² desalination system, Staby redirected RME's focus to water desalination. Due to the increasing global demand for drinking water, the number of companies entering the desalination space was growing rapidly as was the development of new technologies. Between 2005 and 2010, the number of desalination technology patents doubled.¹³ A growing number of companies were exploring the use of renewable energies to power desalination plants to cut down on operational costs and harmful CO₂ emissions. Nearly one-third of all renewable energy desalination patent families had originated since the mid-2000s.¹⁴ Many companies were involved in the desalination industry, including industrial giants like GE, Siemens, Dow Chemical, and South Korea-based Doosan, which was overseeing the world's largest seawater desalination project in Saudi Arabia to provide drinking water to Riyadh and 2,400MW of power.¹⁵ Other desalination players included U.K.-based Biwater, which was heavily active in running desalination plants in remote island locations, including Tortola and the Maldives. IDE, based in Israel, was building desalination plants domestically as well as in China and India.¹⁶

In 2008, Staby pitched his idea of wave energy desalination at the MIT \$100K Entrepreneurship Competition. Ceberio, who became COO in August 2009, was part of the team that joined Staby in carrying out market research and developing a business plan. His research solidified Staby's decision to pursue the water market. By United Nations Development Programme (UNDP) estimates, 1 billion people lacked access to clean and safe drinking water; and experts believed that by 2025, 50% of the world's population would be living in countries with contaminated or insufficient water resources.¹⁷ Ceberio's due diligence suggested a gap in the fresh water production market between utility-scale, on-grid solutions (dams, pipelines, power plants) and micro-scale solutions, those that met the needs of only a few people. Based on his research, Ceberio believed RME should target countries that lacked low-cost fresh water resources and on-grid electricity or low-cost alternatives, but had an adequate supply of wave energy resources. With these criteria in mind, four countries leapt out: Morocco, Yemen, Indonesia, and South Africa.

Ceberio's research indicated that a wave-energy-generated water market extended beyond developing countries. It included the military, disaster relief organizations, and eco-resorts in the Caribbean, Indian Ocean, and Pacific islands, which were too small to meet the water demands of both locals and tourists, and where water at luxury resorts could cost as much as \$6.00/m³. However, the company chose South Africa as its launch market for several reasons. With a population of 50 million people,

¹² Reverse osmosis is a process which forces saltwater through a membrane in order to filter out salt and impurities.

¹³ Erica Gies, "Company Aims to Desalinate Fracking Water," *Forbes*, June 4, 2012.

¹⁴ Helena van der Vegt, Ilian Iliev, Quentin Tannock, Sarah Helm, "Desalination Technologies and the Use of Alternative Energies for Desalination," *CambridgeIP*, November 2011.

¹⁵ Ed Attwood, "Doosan to Build the World's Biggest Desal Plant in Saudi," *ArabianBusiness.com*, September 1, 2010.

¹⁶ "The 2011 Global Water Awards: Desalination Company of the Year," *Global Water Intelligence*, February 2011.

¹⁷ Don Seiffert, "High-water Mark: Cleaning and drawing energy from water gains traction," *Boston Business Journal*, January 6, 2012.

over 21 million South Africans lived in water-stressed areas and, of that population, nearly 2 million lived on the coast and were either connected to weak electric grids or were off the grid altogether. As Staby explained, “It’s a country that’s got one foot in the developed world and, yet, is still a developing country in many ways. And the blacks in South Africa, who hold the key political positions, are determined to address the post-apartheid inequalities that still exist there.”

RME estimated that South Africa represented a \$1.4 billion market. (See **Exhibit 4**.)

Wave₂O™

Still in the prototype stages and awaiting its second ocean trial, the Wave₂O™ was made up of three components. (See **Figure 2**.) The off-shore oscillating WEC, which sat fully submerged just outside the surf zone, consisted of a paddle (16.5 feet wide, 13 feet high) that swung back and forth with each passing wave delivering seawater to shore through a subsea pipeline. Approximately 10% of the energy in the water that moved through the pipeline was converted into the electricity that was necessary to run the control system and valve actuators.

The second component was the flow smoother/pressure intensifier, which reduced flow fluctuations and intensified hydraulic pressure generated by the WEC to levels required to pump seawater from the desalination intake (beach well) to the pretreatment system and into the RO membranes. The diluted brine, a byproduct of the desalination process and the seawater used to transfer the wave energy to the desalination plant, was discharged back into the ocean. According to Ceberio, the salinity of the discharged water would be no more than 10% greater than ambient ocean water, making it environmentally safe.

The final component was the desalination plant that used standard seawater RO membranes and other off-the-shelf components.¹⁸

¹⁸ Nikolay Voutchkov, “Independent Expert Report on Wave-Energy Desalination System Developed by Resolute Marine Energy,” *Water Globe Consulting, LLC*, December 2011.

Figure 2 Wave₂O™ Powered by Hydraulics

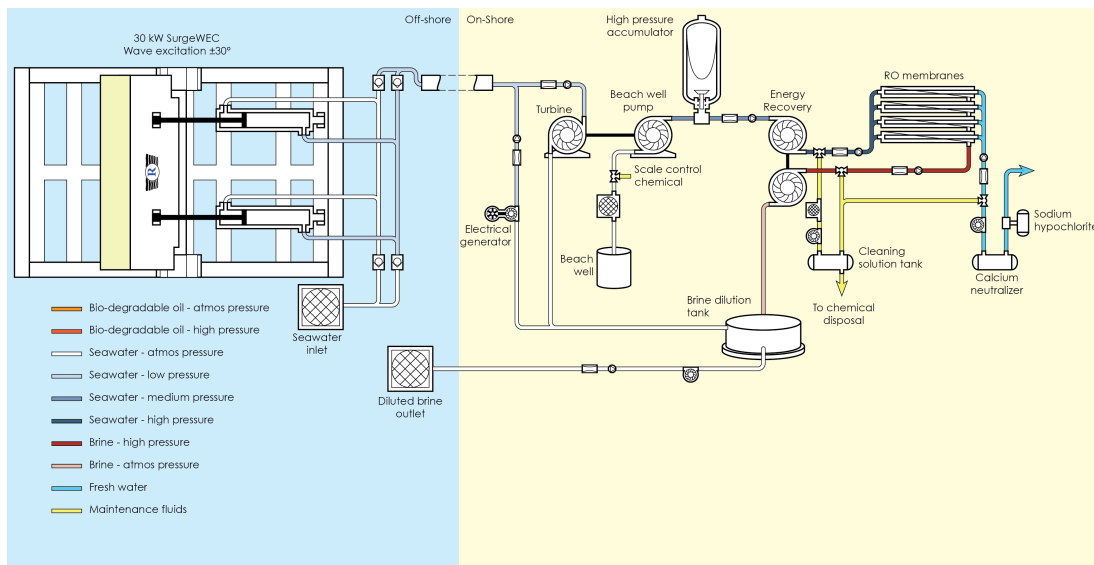
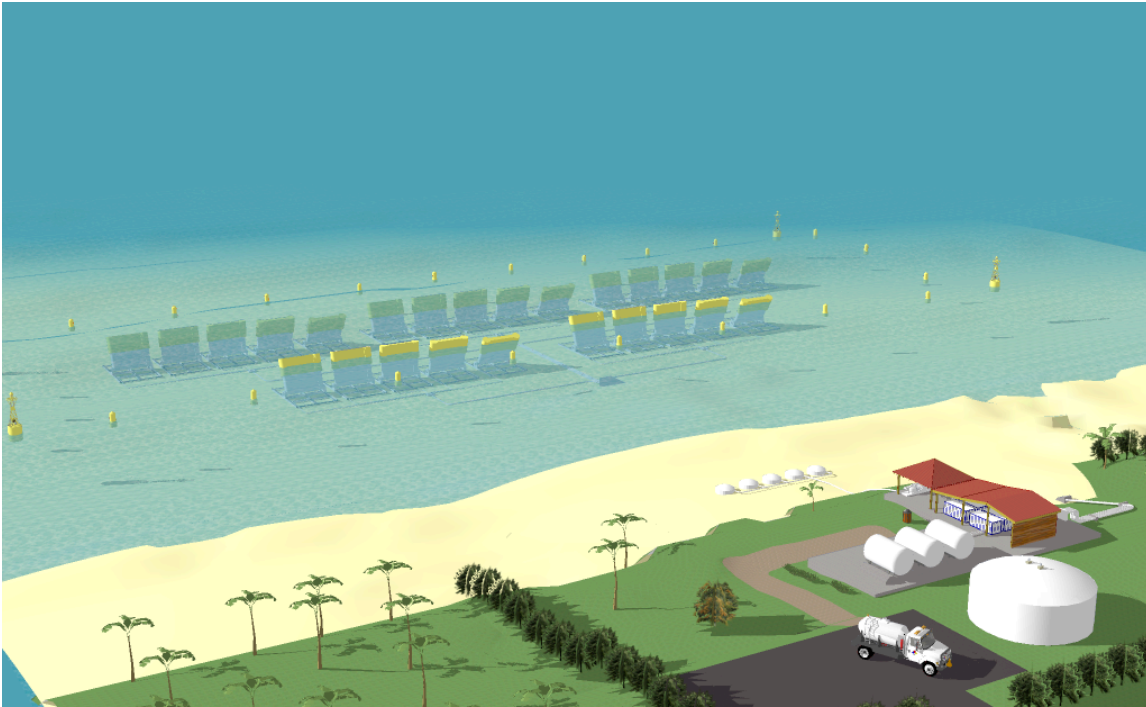

Source: RME.

Two of the key benefits of the Wave₂O™ were its size—one WEC unit could fit into a standard marine container—and its scalability—one unit could produce enough water for 850 people, and a plant of 25 (as depicted in **Figure 2**) could meet the needs of 21,400 people. From the customer perspective, the price of water produced from the Wave₂O™ was arguably the biggest selling point: between \$1.00 and \$2.00/m³. Off-grid communities that relied on diesel generators to run desalination plants could pay anywhere from \$3.00 to \$8.00/m³ for fresh water.

Intellectual Property

RME's intellectual property portfolio was extensive in part because the company had a registered patent agent on staff. Art Williams, a 30-year veteran of IBM who held a PhD in theoretical physics, was responsible for identifying areas where the filing of RME patent applications would yield value and for writing and filing RME patent applications pertaining to new inventions. By mid-2012, RME had filed 10 provisional patents and three Patent Cooperation Treaties (PCTs).¹⁹ (See **Exhibit 5**.) Provisional patents were notarized lab notebooks registered with the U.S. Patent and Trademark Office, which gave the filer 12 months to file a PCT and/or a national patent with the priority date of the provisional. A PCT application was relatively inexpensive and provided significant value, even when it was allowed to lapse. By publicly disclosing the invention, the PCT prevented others from patenting the idea, everywhere and forever, thereby preserving freedom of action. National patents were significantly more expensive, but provided the important additional benefits of cross-licensing value and monopoly exploitation in a single country.

While RME had not filed for any national patents—considered the third and final phase of the patent application process—the company was thinking about filing for one in South Africa. Williams believed that, in general, it was often not cost-effective for small technology companies to go beyond the PCT stage and file national patents, which could cost up to \$15,000 per country. As he put it,

I think most of the benefit comes from the PCT, which preserves your freedom of action. The benefits from spending all the money to keep your competitors from acting on your idea country-by-country only comes into play when somebody's making money off it, because that's the basis for an infringement penalty. I think that deferring spending a lot of money is very important for startups.

Financing

As of spring 2012, with the exception of \$400,000 raised from private investors and the \$50,000 RME won from the 2011 MassChallenge business plan competition, the vast majority of RME's financing had come from the public sector, specifically the U.S. Department of Energy and the Department of the Interior.

¹⁹ Patent Cooperation Treaty.

RESOLUTE MARINE ENERGY: POWER IN WAVES

Cate Reavis, Ezra Zuckerman

Founders and employees	Aug-09	\$116,000	—
Department of Energy	Aug-10	\$1,250,000	WEC development
Private Financing	Jun-11	\$400,000	Tank testing; first ocean trial
Department of the Interior	Sep-11	\$37,000	Complete development of subsystem of Wave ₂ O™
MassChallenge	Oct-11	\$50,000	—

In order to complete the pre-commercialization pilot process for the Wave₂O™, RME would need more money. The company was looking for \$6 million to fund the system's second ocean trial, which it hoped to carry out in late summer 2012, and to complete an integrated pilot in South Africa, which was expected to take 18 months. Finding investors with "patient money," particularly on the heels of the global financial crisis and recession and, as Staby put it, the wave energy industry's bad reputation among venture capital (VC) firms, would be challenging. "It's just a practical reality of renewable energy companies that they take a lot of capital and require long timelines to develop their technologies," Staby remarked. "If you're going to survive, you better find financing sources that are willing to fund you through the development stage."

Staby and Ceberio believed that RME would have the most success with impact investment funds. Traditional VC firms were interested in quick financial turnarounds. Impact investment funds, however, tended to have a longer time horizon in recouping investment and to focus on companies with social missions, such as RME. As Staby noted, "Impact investment funds are measured not only on the financial returns they provide their limited partners, but also on the social and environmental benefits they create. Water is a life and death thing." RME believed investors in the \$6 million Round B of financing who exited in 2015 would earn a 5x return of capital and a 70% internal rate of return.

The key would be finding investors interested in the water crisis afflicting Ugu, South Africa.

Ugu

In early spring 2012, RME signed a non-binding memorandum of understanding (MOU) and a non-disclosure agreement (NDA) with the municipality of Ugu to deploy a wave energy desalination pilot in 2013. RME's deliverables would include one WEC and one desalination plant. The targeted production capacity was 50m³/day. If the pilot proved successful, Ugu would buy the first Wave₂O™ system. As part of their agreement, RME would be responsible for manufacturing, installing, and maintaining the Wave₂O™ (revenue would come from equipment sales and maintenance), and Ugu would be responsible for operating the system and water distribution.²⁰

²⁰ This arrangement would be different if and when RME entered a developed luxury market, such as a Caribbean island, where the company would also produce the water.

By RME’s estimates, Ugu would need as many as 17 Wave₂O™ systems to meet the municipality and Department of Water Affairs’ goal of providing 0.5m³/day of additional fresh water to every household in rural areas. Approximately 61,000 households in Ugu lacked safe drinking water.

Along with signing an MOU and an NDA with the municipality of Ugu, RME had also signed an NDA with South Africa’s Council for Scientific and Industrial Research (CSIR), a scientific and technology research, development, and implementation organization, to provide technical and engineering expertise for the pilot.

Upon learning about the Wave₂O™ pilot partnership among RME, Ugu, and CSIR, the Development Bank of South Africa (DBSA) expressed interest in helping to fund the South African side of the project: namely for technical expertise and site development. (See **Figure 3** for responsibility and cost breakdown among the partners.) In July 2012, Ugu began the process of applying for a DBSA grant worth \$1,200,000. Assuming Ugu received the grant, which RME hoped would be by early fall 2012, the MOU with RME would become binding.

Figure 3 Cost Responsibilities for Each Partner

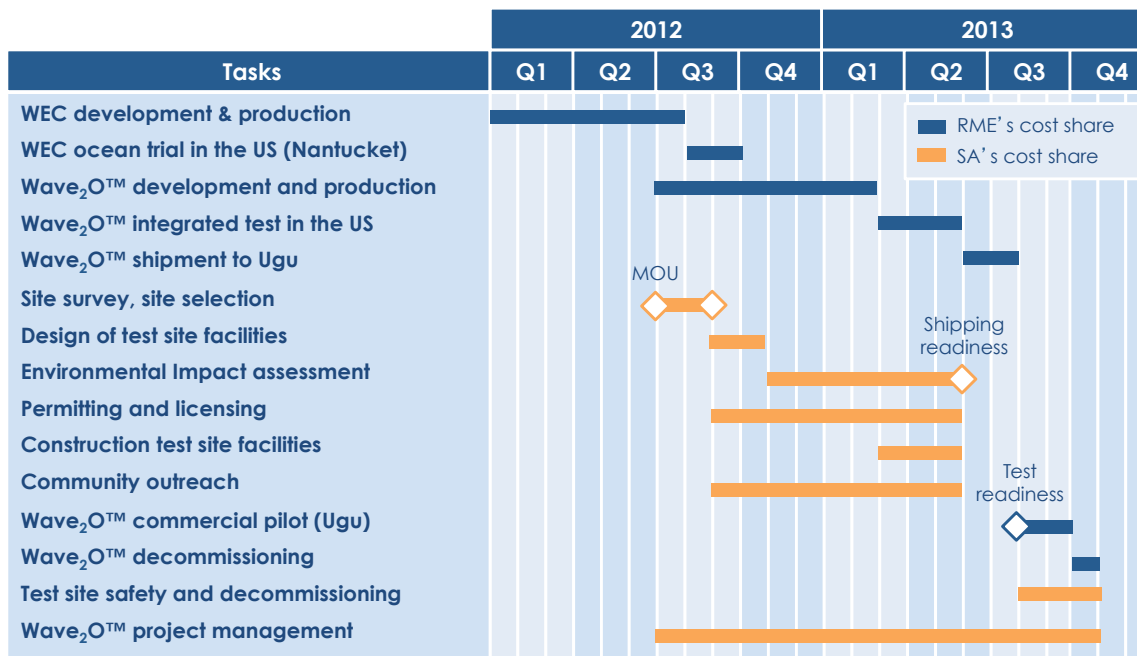

Source: RME.

Looking beyond the pilot, RME estimated that by the end of FY 2016, it would have 15 plants up and running, providing over 320,000 people in Ugu with fresh water, and that its revenue and net income would top \$72 million and \$10.4 million, respectively. (See **Exhibit 6** for key economic and financial figures.)

Alaska

While Ceberio was establishing partnership agreements in South Africa, Staby was pursuing a potential opportunity in Alaska. Though RME's primary focus was the water market, the company was interested in learning more about providing electricity to niche markets, namely those off the grid that were dependent on diesel generators—at \$8.00 a gallon—for electricity generation. There were many remote communities in Alaska fitting this description, where electricity could cost as much as \$0.60/kWh and, as a result, was suffocating economic activity and any potential for economic growth. (NSTAR's basic fixed rate was \$0.07/kWh.) As Staby explained, "Many who live in these communities end up leaving to go somewhere else because there's no manufacturing or retail base, and the power costs are too high."

Staby recognized that time was not on RME's side. The required permitting and environmental studies would take three to four years, after which RME would be able to begin deploying equipment. On the upside, Staby was confident that the company would get funding from the Department of Energy to begin building a system, and was preparing to apply for a \$500,000 grant. Alaska would act as a learning platform for RME to gain experience with project development. As Staby explained,

Up until now, all of our work has focused on technology development. We're now at a key inflection point in our corporate history because we're adding project development to our business model, which introduces a whole new set of challenges to address and skills to build. Because Alaska is subject to all the same regulatory and permitting requirements as the 'Lower 48,' one of the key lab experiments we'd like to conduct is how to get through this process quickly and cost-effectively.

Another key learning platform would involve market development. Because no formal market studies indicated the potential for wave energy technologies to supplant or supplement existing diesel generators to provide electricity to remote communities—or penetrate new markets where no electricity generating capacity existed—the Alaska project would enable RME to test what Staby's intuition told him was a viable market opportunity.

Staby was confident that pursuing an opportunity in Alaska would not be a distraction to RME as the company attempted to enter the South African water market. "We are looking at two different strategic directions," he explained. "At this point, we don't see them canceling each other out in any way. Assuming we get the grant money we need, we think we can cover both at the same time."

But Ceberio wondered how a dual work stream for a small startup might look to potential investors: “If we start to work now with two work streams, one to produce electricity, the other one to produce water, will investors start to ask the question, ‘Okay, where did I invest my money?’ Should we think about being more disciplined, or should we position ourselves so that we have a greater chance for getting free grant money from the U.S. government?”

Three Potential Approaches

With its pilot delivery date in Ugu only 18 months away, Staby, Ceberio, and the RME team were well aware that the company would have to decide on a strategic approach for entering South Africa. There were three viable options.

Approach #1: WEC That Produces Electricity

The first approach would be to develop a WEC that produced electricity, to which an off-the-shelf desalination system, of which there were many, was attached. This was arguably the easiest approach due to the fact that desalination systems were powered by electricity and that less on-site equipment modification would be needed. This approach was also tempting due to the availability of U.S. government grants to develop wave energy-generated electricity, and was made all the more appealing due to the lack of enthusiasm from the VC community for renewable energy. Furthermore, RME had already been quite successful in getting grants from the Department of Energy and the Department of the Interior. Despite the lack of commercial success, electricity produced by wave energy was a known and well-tested technology.

There were, however, a number of drawbacks. First, there was the pricing issue. Because RME’s system would be producing the electricity required to run a desalination plant, it would most likely have to price the system’s output at the cost of electricity and not water, which would significantly cut into RME’s profit margins. (See **Exhibits 7a** and **7b**.) As Ceberio noted, “When you are off-grid, the premium that people are paying for water is much higher than the premium that people pay for electricity because water is a biological need.”

Another drawback to powering a desalination plant with electricity was that it was a less “clean” option because the brine created as a result of the RO process would have to be disposed of somehow. (See **Figure 4**.) Unlike a hydraulic system, the brine would not be pumped back into the ocean. In addition to being less clean, a system that produced electricity for a desalination plant would lose efficiencies due to the need to convert hydraulic power into electricity and back to hydraulic.

There were concerns that an electricity-producing WEC could become a victim of “plug and play.” As Ceberio explained, “If we have a commercial product that produces electricity, nothing would prevent another company from buying this system, attaching a desalination system to it, and capturing the value of creating water. In this case, we could make a profit of \$0.05 per kilowatt hour, and our customer would make \$0.50 per cubic meter of fresh water. If you assume that we need 3 to 4

kilowatt hours to produce 1 cubic meter of fresh water, our customer would capture most of the value created.”

Then there were competitive concerns. A number of large players—Aquamarine, in particular, which had a lengthy list of funders including multinational ABB—had been focusing on the electricity market for many years and had a lot of capital. One of these companies could conceivably enter the market and quickly overpower RME’s position.

Finally, by focusing on electricity production, RME would be selling to one customer, Eskom, South Africa’s national electricity provider. A single-customer market would severely limit RME’s bargaining power. Because municipalities in South Africa oversaw the water needs of their own populations, the water market had a broad customer base.

Figure 4 Desalination Plant Powered by Electricity

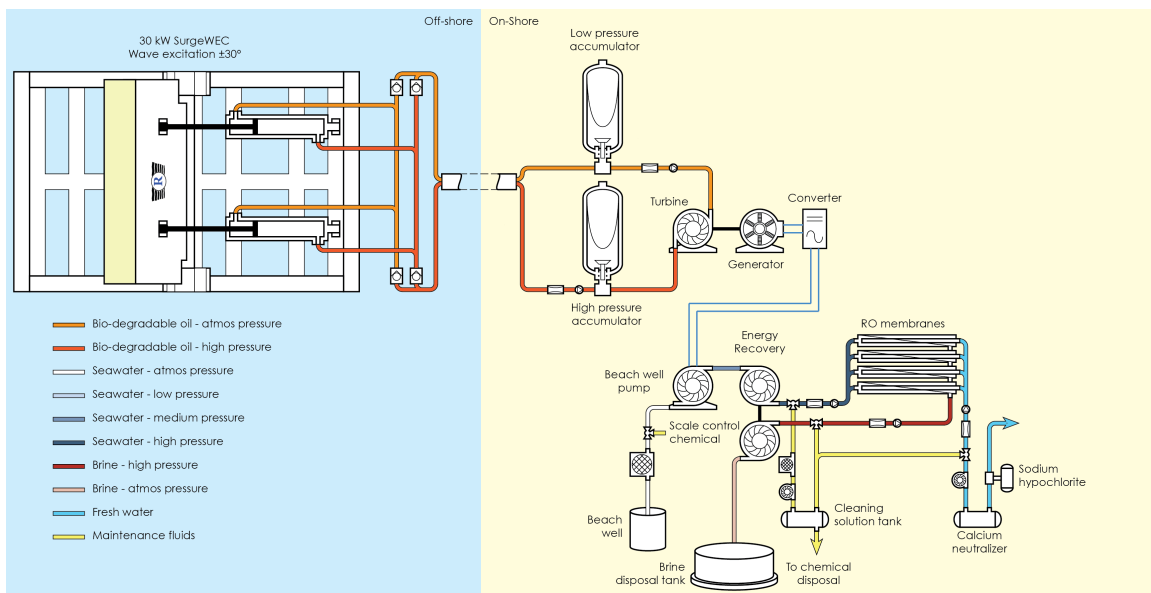

Source: RME.

Approach #2: WEC That Produces Hydraulic Power

Even though RME considered building an electricity-generating system as one strategic approach, its business plan indicated that the company’s wave-powered system would use hydraulics to power a desalination plant. An all-hydraulic system had many advantages. It was a cleaner option since the diluted brine would be sent back into the ocean and would not have to be disposed of on land. It was also more efficient since less energy conversion would be required. As a result, according to Ceberio, production costs would be 30% lower than going the electricity route. RME would be able to price its product at water prices since its system relied on hydraulic power, not electricity, for the desalination

process, which would mean gross margins of \$4 million over a 20-year period. By focusing strictly on hydraulics, RME would be facing few, if any, direct competitors in South Africa. Because most of the big players in the space were focusing on electricity generation, there was greater potential for RME to get IP protection for its hydraulic system.

One of the main downsides to going all hydraulic was money. Because U.S. government grants for wave-powered energy focused on electricity generation, RME would have to turn to private investors to raise the \$6 million that would be needed to pilot the Wave₂O™ system. At a time of ongoing global economic instability and a certain level of dismissiveness among the VC community about the financial potential of wave-powered energy, raising the money would be challenging. It was fairly clear that the company would have the most success with impact investors who, while wanting a financial return on their investment, were also interested in the social impact of their investment. And with the recent commitment from the DBSA to fund the South African part of the pilot, RME would likely look more appealing.

In addition to money, RME faced potential technological challenges. Developing a WEC system that produced hydraulic power instead of electricity was a unique approach and, by definition, was an untested technology. This approach would negate the possibility of buying an off-the-shelf, RO desalination system that ran on electricity, and would require partnering with a desalination company, which would have to develop a new, or modify an existing, system to run on hydraulic power.

Approach #3: The Black Box

RME was also contemplating developing a “black-box” system. Vertical integration would enable RME to own the entire water production value chain and would not require a desalination partner. By owning the entire system, RME would be able to sell hybrid desalination systems that produced both fresh water and electricity, without being a victim of “plug and play.” In the case of Ugu, such a hybrid system would enable RME to produce fresh water and use electricity to pump it into the existing distribution network reaching inland communities and opening new potential for growth. Owning the entire system would also enable RME to optimize the wave-driven desalination technology at a system level and create new sources of innovation and IP.

However, there were some downsides to this approach. An all-in-one solution would require more capital and time to develop. Depending on the extent to which RME wanted to bring manufacturing of the desalination system in-house, the company would need to equip its team with desalination technology experts. Pricing was another hurdle. Could RME charge water prices for a system that could also generate electricity? And would a hybrid approach be confusing to investors, who might wonder if they were investing in water or electricity production?

Another disadvantage to the black box approach was that RME would be entering South Africa without a local partner who could bring business connections and access to local money.

Furthermore, a local partner would have the experience that RME lacked in selling water to South African municipalities. The financial drain of teaming up with a local partner would likely be minimal since desalination technology, according to Ceberio, was approaching commodity status. In other words, a desalination partner would not have a lot of bargaining power.

Lastly, assuming RME was interested in being acquired by a large company involved in the desalination business, such as GE or Siemens, did it make sense to develop a black box solution?

Conclusion

Three years after RME began focusing on how its technology could serve the multibillion-dollar global water market, the company was at a critical juncture in deciding on how best to position itself. When it came to South Africa, RME had identified three market-entry approaches, each of which had its own short-term and long-range advantages and disadvantages. Besides deciding on the best course of action involving startup funding and technology, not to mention the best way of fulfilling the needs of the people of Ugu, RME also had to keep in mind an exit strategy.

Whichever strategic approach RME decided on would help it further define what kind of company it wanted to be. The key question was: Which approach would best serve current stakeholders and attract potential investors?

Exhibit 1 RME Team Bios

Management Team

William Staby – Chief Executive and Founder

Bill is a seasoned entrepreneur with leadership experience gained at global enterprises, including Credit Suisse, Xerox, and Rabobank International. Since 1998, he has served as founder, CEO, and CFO of several startup technology companies—one of which had a successful IPO. Bill is a member of the Ocean Renewable Energy Coalition in Washington, D.C.; chair of the U.S. delegation to the IEC TC-114 Technical Standards Committee in Geneva, Switzerland; and a member of the Advisory Board of the Coastal Studies Institute in Manteo, NC. A dual U.S./Swiss citizen, he holds an MBA degree from New York University.

Olivier Ceberio – Chief Operating Officer

Olivier is an aeronautical engineer with significant product development and project management experience gained at Starsem, where he led the successful development, production, and launch of a Russian rocket vehicle, which enabled the market entry of a revolutionary system that became Starsem's commercial mainstay. Prior to RME, Olivier worked for eight years in Russia, Kazakhstan, and Indonesia. He was employed by the World Bank and also worked in microfinance in India. Olivier is a dual MBA/MPA graduate of MIT Sloan School of Management and Harvard Kennedy School of Government, and holds an MS degree in aerospace engineering from Institut Supérieur de l'Aéronautique et de l'Espace (SUPAERO).

Pat Rezza – Chief Technology Officer^[SEP]

Pat is RME's Senior Hydraulics Engineer with more than 25 years of systems experience in high technology, clean technology, and renewable energy enterprises including Kaman Electromagnetics, Intel Corp, Stratalight Communications, and Premium Power Corporation. Pat has lead large multi-disciplinary engineering teams in the development, integration, testing, and deployment of advanced electric drive systems, power conversion systems, and grid-scale energy storage systems each containing complex hydraulic systems. Additionally, Pat has extensive experience in managing manufacturing and supply chain operations in both entrepreneurial (4 start-up companies) and Fortune 500 companies (Intel and Kaman Corporation). In addition to technology development and operations experience, Pat has extensive international business development, M&A, and board/corporate governance experience gained from over 7 years at Intel (Intel Capital and Director of Business Development, and as VP of Business Development at ArrayComm, LLC). Pat holds a MS degree in mechanical engineering from MIT and an MBA from Harvard Business School.

Technical Team

Clifford Goudey – Lead Engineer, Wave Energy Systems

Cliff has over 30 years of experience in developing a wide range of technologies for working on and under the ocean. A consistent theme of his work has been the introduction of innovative ways to tap the productivity of the ocean in more sustainable ways. Cliff spent 25 years as a research engineer at MIT Sea Grant College where he was director of the Offshore Aquaculture Engineering Center. Cliff holds six U.S. patents, and is the inventor of one of RME's innovative WEC designs. He holds SM degrees in naval architecture and mechanical engineering from MIT, and is widely published on equipment topics related to commercial fishing, aquaculture, marine systems, and underwater robotics.

Allan Chertok – Lead Engineer, Power Take-Off Systems

Allan has more than 40 years of experience in electrical systems engineering and product development management. He has conceived and directed the development of linear permanent magnet alternators, power electronic converters, high-torque/high-speed permanent magnet electrical machinery and control systems, inductive power and data transmission couplers, and wind turbine power and instrumentation systems. His background in electrical systems and his in-depth knowledge of electrical machinery, power electronics, digital control and instrumentation systems are vital to the successful working design of the Wave₂O™. Prior to RME, Allan had a long and successful career at well-known engineering firms, including TIAX, Arthur D. Little Technology & Innovation Group, and U.S. Windpower, where he was a member of the startup technical team. He holds an MS degree in electrical engineering from New York University.

Dr. Lewis Girod – Lead Engineer, Sensor Systems and Data Acquisition

Lewis earned a BS in mathematics and an MEng in computer science from MIT in 1995. After working at MIT/LCS for three years, he joined Deborah Estrin's group as a PhD student at the University of California, Los Angeles (UCLA) in 1998. From 2000 to 2003, he worked full-time at Sensoria Corporation on several commercial and DARPA-funded embedded and sensor network projects before returning to complete his PhD at UCLA in 2005. Lewis returned to MIT as a postdoctoral researcher in 2006, and since February 2008 has been a research scientist at the MIT Computer Science and Artificial Intelligence Lab (CSAIL) while working part-time at RME.

Andrew Bates

Andrew is a senior at Northeastern University (2013). He is currently working at Resolute Marine Energy through Northeastern University's COOP program, which provides students with three six-month opportunities to gain real-world work experience during a five-year degree program. Previously, Andrew worked at QinetiQ and iRobot before joining RME in the spring of 2012. Outside of RME, Andrew spends most of his time mentoring high school students on a FIRST Robotics Team.

Brian O'Rourke

Brian is completing an MS degree in mechanical engineering at Boston University. He currently supports Pat by developing RME's in-house FEA capabilities. Previously, Brian worked as an engineering intern at Terrafugia after a number of years working in education as a teacher, administrator, and principal.

Dr. Arthur Williams – Patent Agent

Arthur is a Dartmouth undergraduate and a Fulbright Scholar and holds a PhD in theoretical physics from Harvard University. He recently retired from IBM Research after 30 years of basic research and technical management. Arthur cofounded a Kleiner Perkins-financed startup based on the exploitation of the Bernoulli Principle of compressible fluid dynamics, and more recently passed the patent bar to become a registered patent agent.

Dr. Jeffrey T. Scruggs – Advisor, Control Systems

Jeffrey is an assistant professor in the Department of Civil and Environmental Engineering at the University of Michigan. His research pertains to vibratory electromechanical systems in which energy efficiency plays an important role. Subsets of such technology include self-powered structural control systems and vibration energy harvesting systems. Jeffrey holds MS and PhD degrees in applied mechanics from the California Institute of Technology and BS and MS degrees in electrical engineering from Virginia Tech. In 2008, he received a five-year CAREER grant from the National Science Foundation to investigate control problems related to vibratory energy harvesting, which has direct implications for the wave energy industry. Jeffrey has served as a technical advisor to RME since 2008.

Dr. Dick K.P. Yue – Advisor

Dick is the Philip J. Solondz Professor of Engineering and Professor of Mechanical and Ocean Engineering at MIT where has been a faculty member in Ocean Engineering since 1983. His main research contributions are in theoretical and computational hydrodynamics. Dick is internationally recognized for his expertise on ocean and coastal wave dynamics and for his extensive work in nonlinear wave mechanics, large-amplitude motions, and loads on ships and offshore structures, making seminal contributions in developing numerical methods for these types of problems. He has authored or co-authored more than 200 papers and a two-volume textbook on wave hydrodynamics and ocean fluid mechanics.

Julianne Zimmerman – Advisor

Julianne provides strategic consulting services to organizations putting technology to work for the greater good. She has been active in the clean/greentech space since 2002 and in technology since 1989, with over 20 years of experience in small and early-stage companies. As VP of Communications at General Compression, a utility-scale energy storage company, she directed corporate identity and oversaw the creation of all communications materials, including investor

presentations, web content, and technical animations. Julianne was previously a member of the three-person startup team and director of Business Development for GreenFuel Technologies Corporation, an algae biofuel company, where she devised and executed the company's communications program and managed the design and on-schedule deployment of the company's first customer field trial. Prior to that, she served as VP of Engineering at Ovation Products, a water purification company.

Nikolay Voutchkov – Advisor

Nikolay has 25 years of experience in the field of seawater desalination and water and wastewater treatment. He is an independent technical advisor and a former chief technology officer for Poseidon Resources Corporation, a private company specializing in the development, financing, and implementation of seawater desalination projects.

Exhibit 2 Profile of Select Wave Energy Players

<i>Company</i>	<i>Year Founded</i>	<i>Location</i>	<i>Employees</i>	<i>Example of Work</i>
OPT	1994	U.S.	51	The U.S. Department of Homeland Security granted OPT \$75,000 to perform ocean tests on its PowerBuoy to demonstrate its use for ocean surveillance.
Aquamarine	2005	U.K.	60	Helped by an ABB investment of \$13 million in 2010, Aquamarine began testing the second-generation Oyster 800 device off the coast of Scotland in June 2012. Once up and running, a farm of 20 Oyster 800 devices would generate sufficient power for up to 15,000 homes.
Oceanlinx	1997	Australia	25	In mid-2012, the Australian government awarded Oceanlinx a \$4 million grant to test its 1MW GreenWAVE device off the coast of Australia.
Wave Dragon	2002	Denmark	>10	In early 2011, Wave Dragon began developing a 1.5MW device suitable for more benign wave climates. The company already had developed 4MW and 7MW devices and planned to deploy the device off the coast of Denmark.
Pelamis	1998	U.K.	50	In 2009, Pelamis entered into a joint venture with Vattenfall, one of Europe's largest utilities, to develop a 10MW wave energy farm off the coast of Scotland.
Carnegie Wave Energy	2005	Australia	NA	In June 2012, Australia's Department of Defense agreed to purchase electricity for its largest naval base (1.25MW/day or enough to power 1,000 homes) from Carnegie Wave Energy.

Exhibit 3a Carnegie Wave Energy Statement of Comprehensive Income, 2012

	Consolidated Group	
	(Restated)	
	2012	2011
	\$	\$
Revenue		
Government grants	228,692	81,437
Other income	201,417	254,837
Employee benefits expense	(1,106,103)	(1,211,740)
Depreciation expense	(98,332)	(130,643)
Occupancy expense	(373,491)	(434,734)
Consultancy expense	(103,679)	(476,798)
Doubtful debts expense	—	3,541
R&D expenses	(111,699)	—
Executive and non-Executive Directors' Fees	(913,423)	(1,150,940)
Shared based payments	(1,131,212)	(2,746,410)
Movement in cash settled share based payments liability	3,041	124,776
Company secretarial expenses	(84,000)	(96,679)
Administrative expenses	(1,008,068)	(975,744)
Other expenses	(25,019)	(13,228)
Loss before income tax	(4,521,876)	(6,772,325)
Income tax benefit/(expense)		
Loss for the year	(4,521,876)	(6,772,325)
Other comprehensive income		
Exchange differences on translating foreign controlled entities	(5,262)	(2,092)
Income tax relating to components of other comprehensive income		
Total comprehensive loss for the year	(4,527,138)	(6,774,417)
Earnings per share		
Basic loss per share (cents per share)	(0.470)	(1.478)
Diluted loss per share (cents per share)	(0.470)	(1.478)

Exhibit 3b Ocean Power Technologies, Inc. and Subsidiaries Consolidated Statement of Operations, 2012

	Year Ended April 30,		
	2012	2011	2010
Revenues	\$5,738,506	6,691,082	5,101,311
Cost of revenues	5,683,731	6,255,437	4,298,955
Gross profit (loss)	54,775	435,645	802,356
Operating expenses:			
Product development costs	8,337,424	13,319,110	13,001,550
Selling, general and administrative costs	8,274,096	8,399,325	9,063,482
Total operating expenses	16,611,520	21,718,435	22,065,032
Operating loss	(16,556,745)	(21,282,790)	(21,262,676)
Interest income, net	418,052	689,276	1,032,484
Other income	—	—	557,540
Foreign exchange (loss) gain	(104,739)	(229,415)	540,644
Loss before income taxes	(16,243,432)	(20,822,929)	(19,132,008)
Income tax benefit	1,053,427	364,105	—
Net loss	(15,190,005)	(20,458,824)	(19,132,008)
Less: Net loss (income) attributable to the noncontrolling interest in Ocean Power Technologies (Australasia) Pty Ltd	49,503	22,950	(38,299)
Net loss attributable to Ocean Power Technologies, Inc.	\$(15,140,502)	(20,435,874)	(19,170,307)
Basic and diluted net loss per share	\$(1.47)	(1.99)	(1.88)
Weighted average shares used to compute basic and diluted net loss per share	10,277,661	10,246,921	10,217,003

Exhibit 4 Analysis of Global Electricity and Water Markets

Water Market: \$9.6B/y
South Africa 1st; 3 other countries above \$1B/year; South hemisphere

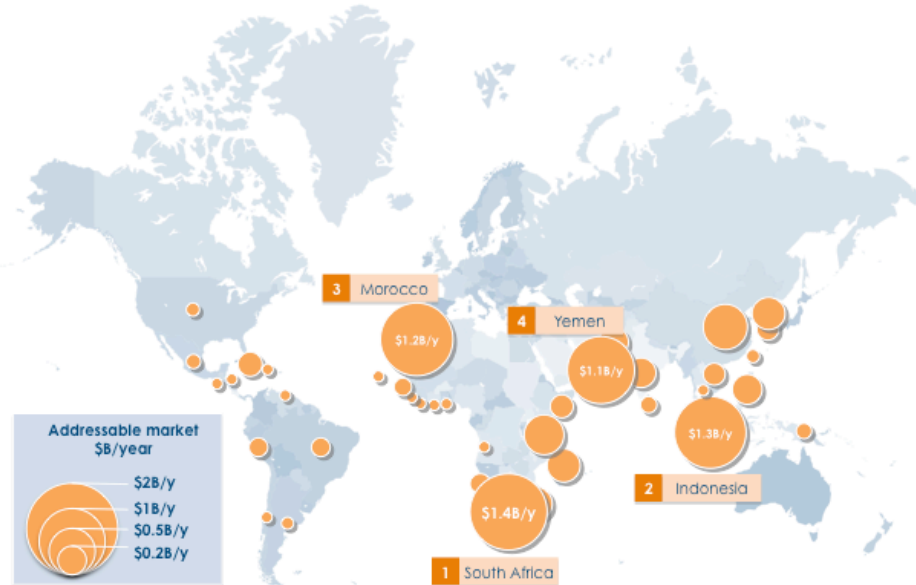

Source: RME.

Exhibit 5 RME IP Portfolio

1. Extendable SurgeWEC Paddle, PCT, 12/23/09

The power generated by a wave-energy converter (WEC) is proportional to the WEC area exposed to the wave motion and to (the square of) the wave height. Wave-height variation can therefore cause the power generated by the WEC to fluctuate undesirably. This patent application covers WECs that allow the surface exposed to the waves to be controllably varied so as to reduce fluctuations in the generated power. The rectangular area of a SurgeWEC comprises overlapping panels. Variation of the panel overlap varies the device area exposed to the waves, thereby reducing fluctuations in the power generated.

2. Single-PTO, Tripod-Moored Point Absorber, Prov

The invention comprises a buoy that moves both vertically and horizontally in response to wave motion. The horizontal motion is in the direction of incident waves. One of the three tripod mooring cables is aligned with the predominant direction of incident waves. This cable is “active” in that it includes a power-takeoff (PTO) subsystem. When wave motion causes the buoy to move

upward and toward the shore, the “active” cable rotates the drum around which it is wound. The drum rotation drives a power-generating subsystem, such as an electric generator.

3. Floating SurgeWEC: Concave Paddles, PCT, 3/18/10

Wave energy converters harness wave motion by means of drag. Drag is greater for concave shapes, such as parachutes, than for convex shapes, such as torpedoes or submarines. Existing WECs are convex or substantially planar. This patent application covers all concave WECs, from point absorbers to SurgeWECs.

4. Floating SurgeWEC: Full Water Column, PCT, 10/21/10

WEC efficiency is lost near the edges of the WEC paddle where the WEC loses its “grip” on the water constituting the wave motion. Additionally, near the edges constituting the periphery of the WEC paddle, the motion of WEC relative to the surrounding water creates vortices and turbulence. Among the edges constituting the paddle periphery, the horizontal edge along the paddle top is the most important. The negative effects of this edge are eliminated by extending the WEC to and through the water surface. A WEC whose top edge floats eliminates turbulence associated with the top edge, allows the WEC paddle to cover the entire water column, and enables the capture of the vertical water motion (heave) internal to waves. Allowing a portion of the WEC paddle to float while capturing the motion all the way to the seabed is challenging. This patent application covers structures that address this challenge.

5. Bellows SurgeWEC Paddle, Prov, 11/2/11, 11324862

SurgeWECs are composed of a paddle, one edge of which is hinge mounted to a stationary platform. Wave energy is captured by converting the wave-driven rotation of the paddle about the hinge axis into a more useful form of energy. The buoyancy of the paddle affects the efficiency with which the paddle responds to the wave action. This patent covers the controlled variation of the paddle volume, and therefore its buoyancy. The paddle comprises two surfaces whose separation is controlled by a variety of means. The separation of the two exterior surfaces of the paddle controls the volume of the paddle.

6. Optimized Control of Multi-PTO WEC Systems, Prov, 8/25/11, 10812173

A WEC array can comprise multiple power-capture devices, such as cables wound around a drum attached to a rotary electric generator. A WEC system can comprise multiple oscillating subsystems, such as arrays of buoy-like absorbers. This patent application covers the application of modern control theory to the optimized control of the multiple power-capture subsystems.

7. Wave-Powered Desalination: System Topologies, Prov, 9/29/11, 11075010

The desalination of seawater by reverse osmosis requires that the input seawater be highly pressurized. The pump providing the pressurization consumes power, which is provided here by a surge-type wave-energy-capture (WEC) device. The power-take-off (PTO) component of the WEC system is used to power the pressurizing pump directly, that is, without the conversion of

the wave power into and back out of electricity. Several improvements are disclosed, including an accumulator in the high-pressure flow, filtration of the seawater input to the PTO, and dilution of reverse-osmosis exhaust by output from the PTO. Some embodiments comprise a closed PTO fluid flow.

8. Arbitrarily Long SurgeWECs, Prov, 6/12/12, 61658718

This invention combines the numerous benefits of relatively narrow SurgeWECs and the great power-capture efficiency of wide SurgeWECs. Narrow SurgeWECs are more efficient to manufacture, transport, and deploy. The power loss due to the ability of the water to avoid the paddle by flowing around its vertical edges decreases rapidly with paddle width, providing a strong benefit to paddle width. The invention consists of wide paddles composed of conveniently narrow modules. Additionally, the phase of the oscillation of individual modules can vary so as to efficiently capture power from waves approaching the SurgeWEC from different directions.

9. Scalable Bellows Pump for SurgeWECs, Prov, 5/14/12, 61646642

This invention is a fluid pump that is especially well suited to both the geometry and functional demands of SurgeWECs. Tubes of flexible material, such as rubber, extend along the SurgeWEC hinge, on both sides of the paddle. Each tube is thus confined between two rigid surfaces; the paddle on one side of the tube, and a stationary surface mounted to the hinge on the opposing side. As the paddle oscillates back and forth under wave action, the tubes alternately fill and empty, as they are expanded and compressed. The two tubes operate 180 degrees out of phase; one tube is compressed, as the other expands. As with a conventional fireplace blower, oppositely directed one-way valves cause water to be drawn into each tube during expansion, and to leave the tube under pressure when the tube is compressed.

10. Smart Management of WEC Arrays, Prov,

The power captured by individual members of a WEC array varies widely on a variety of time scales. Management of the aggregation of the power captured by the individual array elements provides an opportunity to reduce the fluctuations and to accommodate the power reduction concomitant with maintenance or replacement of component WECs.

11. Flexible, Eiffel-Tower Shaped SurgeWEC

A SurgeWEC paddle is a cantilever. The structural strength of a cantilever is maximized by a width that decreases nonlinearly with distance from its support, that is, like the Eiffel Tower. Additionally, the paddle motion creates less turbulence if the cantilevered paddle flexes in a manner similar to the velocity profile of the wave action to be captured. The desired flexibility is achieved by several structures, some active and some passive.

Exhibit 6 Key Economic and Financial Assumptions and Results for the Wave20™ System

	Value
Wave climate	
▪ Average power (deep sea)	20 kW/m
▪ Deep sea to shore losses	30%
▪ Period	6 sec
▪ Wave height	3 m
▪ Wave train duration	19 h/day
WEC	
▪ Efficiency	40%
▪ Width	5 m
▪ Replacement rate	10%/year
▪ Manufacturing cost (initial)	\$51,200
▪ Hydraulic PTO efficiency	80%
▪ Power rating (mechanical)	28.95 kW
Plant description	
▪ Number of WECs for operations	25
▪ Number of additional WECs for continuity	2
▪ Off-shore footprint	2,000 m ²
▪ Average operation time	18.5 h/day
▪ Average daily production	1,789 m ³ /day
▪ Average daily production per WEC	71.6 m ³ /day/WEC
▪ People impacted per plant	21,247
Plant economics	
▪ Method: discounted cash flow	
○ Discount factor	5.5%
○ Lifetime	20 years
○ Terminal value	\$0
▪ Number of WECs already installed	250
▪ LCOW without RME profit	\$0.97/m ³
▪ LCOW with RME profit	\$1.44/m ³
▪ Payback period for municipalities	10.56 years

Installation costs

- Hardware
 - To RME \$0.98M
 - To desalination provider \$1.75M
 - To water utility (customer) \$0.55M

- Shipping and handling
 - To RME \$140K
- Labor
 - To RME \$55K
 - To desalination provider \$4K
 - To water utility (customer) \$25K

Recurring costs

- Hardware
 - To RME \$144K/year
 - To desalination provider \$148K/year
- Shipping and handling
 - To RME \$16K
- Labor
 - To RME \$2K
 - To desalination provider \$3K
 - To water utility (customer) \$55K

Pricing strategy

- Plant installation \$275,000/WEC
- Maintenance premium (of costs) 15%

Revenue and cost breakdown of a 25-WEC plant

- Revenue:
 - Installation \$6.9M
 - Operations and maintenance \$4M
- Installation costs to RME
 - Desalination system (hardware) \$1.75M
 - Wave Energy Converters (hardware) \$0.97M
 - Shipping and handling \$0.14M
 - Labor \$0.06M
 - Total costs to RME \$2.92M

RESOLUTE MARINE ENERGY: POWER IN WAVES

Cate Reavis, Ezra Zuckerman

▪ Operations and maintenance costs to RME (20 years, discounted)	
▪ Desalination system (hardware)	\$1.95M
▪ Wave Energy Converters (hardware)	\$1.86M
▪ Shipping and handling	\$0.21M
▪ Labor	\$0.03M
▪ Total costs to RME	\$4.05M
▪ Gross Margin over lifetime (20 years)	\$3.96M

Financials and other metrics in 2015

▪ Investment for production capacity	\$1M/100 WECs
▪ Sales: Number plants installed	15
▪ Revenue	\$72M
▪ Operating cash flow	\$9.9M
▪ People impacted	320,00
▪ CO ₂ removed (ton/year)	36,600
▪ Cars removed	7,000

Exit

▪ Exit valuation	\$143M (2x revenue)
▪ Exit date	2016
▪ IRR	
○ Round A investors – Seed round (\$400K)	43%
○ Round B investors – Convertible note (\$1M)	58%
○ Round B investors – Preferred stock (\$5M)	51%
○ Round C investors – TBD (\$20M)	61%
▪ Multiplier	
○ Round A investors – Seed round (\$400K)	12.3x
○ Round B investors – Convertible note (\$1M)	6.2x
○ Round B investors – Preferred stock (\$5M)	5.3x
○ Round C investors – TBD (\$20M)	2.6x

Exhibit 7a Levelized Cost of Water

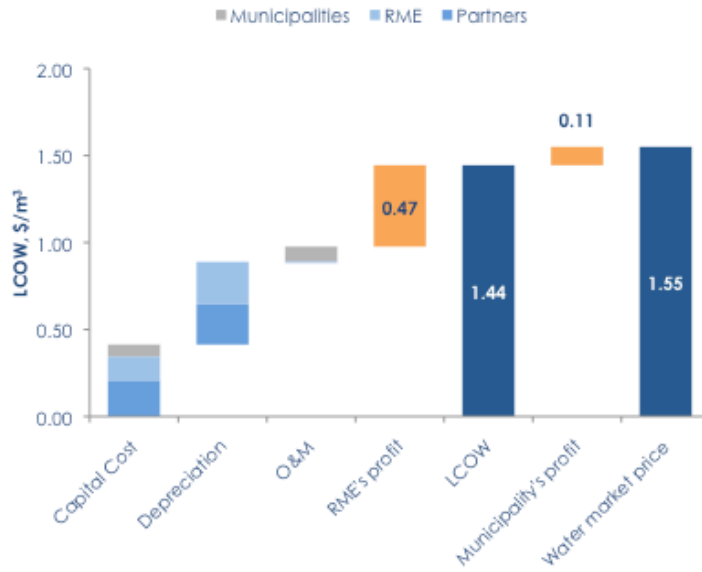

Revenue stream Plant commissioning: \$6.9M Maintenance contract: \$4.0M
Gross Margins (20-year) \$4.0M
LCOW \$1.44/m³
Payback 10.6 year
Pricing strategy \$275K/WEC

Exhibit 7b Levelized Cost of Electricity

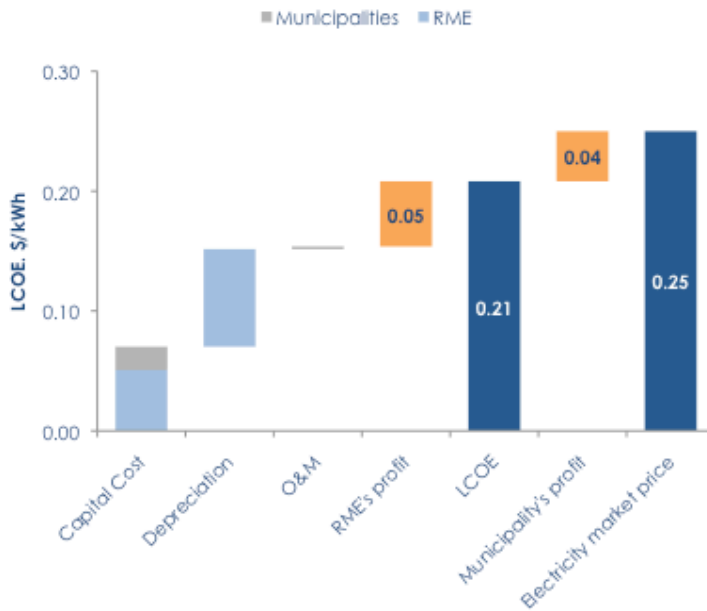

Revenue stream Plant commissioning: \$3.4M Maintenance contract: \$2.8M
Gross Margins (20-year) \$1.6M
LCOE \$0.21/kWh
Payback 10.6 year
Pricing strategy \$115K/WEC

Source: RME.